



MODEL 106  
MODEL 106F  
MODEL 106S

FLO-SENSORS®

## **Installation Manual & Operating Instructions**



**READ THIS MANUAL COMPLETELY BEFORE ATTEMPTING TO CONNECT OR OPERATE YOUR FLO-SENSOR. FAILURE TO DO SO MAY RESULT IN INJURY TO YOU OR DAMAGE TO THE FLO-SENSOR.**

© COPYRIGHT 2006 R.D. MCMILLAN COMPANY, INC.

TABLE OF CONTENTS

---

A. Introduction	3
1. Unpacking	3
2. Product Overview And Principle Of Operation	4
3. Non-Standard Products (Z Suffixes)	5
B. Installation	5
1. General Considerations	5
2. Mounting The FLO-SENSOR®	7
a) Mounting The Model 106 FLO-SENSOR®	7
b) Mounting The Model 106 Using An Optional Base Plate	8
c) Mounting The Model 106F and Model 106S	8
3. Tubing Connections	9
a) General	9
b) Special Considerations For The Model 106	9
4. Electrical Connections	10
a) Overview	10
b) Pulse Output Units ("A" and "E" Suffixes)	11
i) NON ISOLATED Output	11
ii) ISOLATED Output	12
c) Voltage Output Units ("B", "D", "J" and "K" Suffixes)	14
d) Current Output Units ("C" Suffix)	15
C. Operation	16
1. Start-Up	16
2. Entrapped Air or Gas	16
3. Flow Readings	16
a) Pulse Output Units	16
b) 0-5VDC Analog Output Units	17
c) 0-10VDC Analog Output Units	17
d) 4-20mA Output Units	18
4. Operating at Flow Rates Outside the Calibrated Flow Range	18
a) Flows Above the Maximum Rated Flow	18
b) Flows Below the Maximum Rated Flow	19
5. Zero Adjustments	19
6. Checking the Calibration	19
7. Calibrating FLO-SENSORS® for different Liquids	20
D. Maintenance And Product Care	21
1. General	21
2. Cleaning and Flushing	21
3. Returning Units For Repair Or Recalibration	22
E. Part Number Information	23
F. Accessories	24
G. Specifications	25
H. Dimensions	26
I. Limited Warranty	32
J. Trouble Shooting Guide	34
K. Contacting McMillan	36

## A. Introduction

### 1. Unpacking

McMillan suitably packages all sensors to prevent damage during shipping. If external damage is noted upon receipt of the package, please contact *the shipping company* immediately. McMillan Company is not liable for damage to the device once it has left the manufacturing premises.

Open the package from the top, taking care not to cut too deeply into the package. Remove all the documentation and contents. Take care to remove all the items and check them against the packing slip. The products should also be checked for any concealed shipping damage. If any shortages or damage is noted, please contact the shipping company and/or McMillan Company to resolve the problem.

*Contents of Box  
(Model 106F shown, 106 and 106S Similar).*



**Caution:** Take care not to *drop* your sensor. Read the installation section of this manual before providing power or tubing connections to the unit. Any damage caused by improper installation or careless handling will not be repaired under warranty (see limited warranty on page 32 for more details).

## 2. Product Overview and Principle of Operation

McMillan Micro Turbine Wheel FLO-SENSORS<sup>®</sup> for liquids are capable of measuring flows as low as 15-100 ml/min or as high as 7.0-50.0 l/min. Highly repeatable results are achieved using a patented Pelton Turbine Wheel flow sensor design. This proven design minimizes zero drift while maintaining fast response and linear outputs with virtually no maintenance.

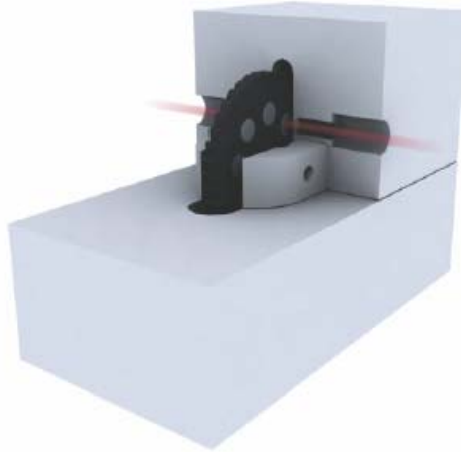

McMillan's patented technology measures flow using a miniature turbine wheel approximately 0.8 inches (20 mm) in diameter. The micro-turbine wheel is supported on a very small sapphire shaft that is held in position by two sapphire bearings. The micro-turbine assembly is so light that it virtually floats in the liquid. This relieves force on the bearings and eliminates wear.

As flow passes through the FLO-SENSOR<sup>®</sup>, a precision machined nozzle directs the fluid onto the very small teeth of the micro-turbine wheel. This causes the wheel to spin at a speed proportional to the flow rate.

The micro-turbine wheel is opaque except for 8 small translucent windows. An infrared light beam is directed onto the wheel through a thin section of the PTFE body. As the wheel rotates the infrared beam passes through each translucent section and is electro optically detected on the other side of the wheel. The detected light is converted to electrical pulses. As the wheel spins faster the pulse rate increases. Processing circuitry provides analog and/or pulse output that are linearly proportional to the flow rate.



When the wheel stops (under zero flow conditions), no pulses are generated. Consequently, zero drift is not possible and zero adjustments are never required.

Every unit is supplied with a calibration certificate detailing the results obtained during calibration. Units are calibrated using deionized water as the reference media. Flowing liquids with different specific gravities or viscosities may yield results differing from the original calibration.

### 3. Non-Standard Products (Z Suffixes)

Please note that the installation instructions, operating instructions, and specifications included within this manual apply to standard production models only. If your FLO-SENSOR<sup>®</sup> has a "Z" suffix (e.g. 106-Z0123) then your unit is non-standard. Contact the factory to check if the installation, operation, or specifications of your sensor are different than detailed in this manual.

## ***B. Installation***



**CAUTION: DO NOT FLOW ANY GAS THROUGH A LIQUID FLO-SENSOR<sup>®</sup>. THIS WILL DAMAGE THE MICRO-TURBINE ASSEMBLY AND VOID THE WARRANTY.**



**Caution: Do not exceed the pressure, temperature or power operating ranges detailed in the SPECIFICATIONS section of this manual. McMillan Company shall not be liable for any damage or injury caused by incorrect operation of their products.**

### 1. General Considerations

It is recommended that a safety shut-off valve be installed upstream of (before) the sensor.

All wetted parts should be checked for compatibility with the liquid to be used. If there are any incompatibilities eg. highly corrosive liquid, then the unit may be damaged or fail prematurely. Such damage will not be repaired under warranty.

Units should be installed in a clean, dry environment with an ambient temperature that is as stable as possible. Avoid areas with strong magnetic fields, strong air flows or excessive vibration.

If the liquid to be used may contain particles larger than 20 microns then a filter (20 microns or less) should be installed upstream of (before) the unit.

If there is any possibility that there may be bubbles or entrapped gas in the system then the outlet tubing should be elevated above the inlet port. This will enable any gas that may become entrapped in the unit to escape.

The required differential pressure (or pressure drop across the unit) decreases exponentially with decreases in flow rate. The specific pressure drop at 100% of the rated flow is detailed on the calibration certificate for each unit.

To calculate the pressure drop at a certain flow rate use the formula

$$PD = (\text{YourFlow} / \text{MaxFlow})^2 \times PD_{\text{max}}$$

**PD** = Pressure drop at YourFlow.

**YourFlow** = flow rate (ml/min or l/min)

**MaxFlow** = 100% rated flow for the sensor (in same units as YourFlow)

**PD<sub>max</sub>** = Pressure drop at 100% rated flow (see calibration certificate)

If the pressure available for the flow sensor is BELOW the pressure drop at the required flow then flow through the unit will not be possible.

*Typical Pressure Drop vs. Percentage of the Full Scale Rated Flow for the Model 106 Series*

*Values may vary +/-10%*

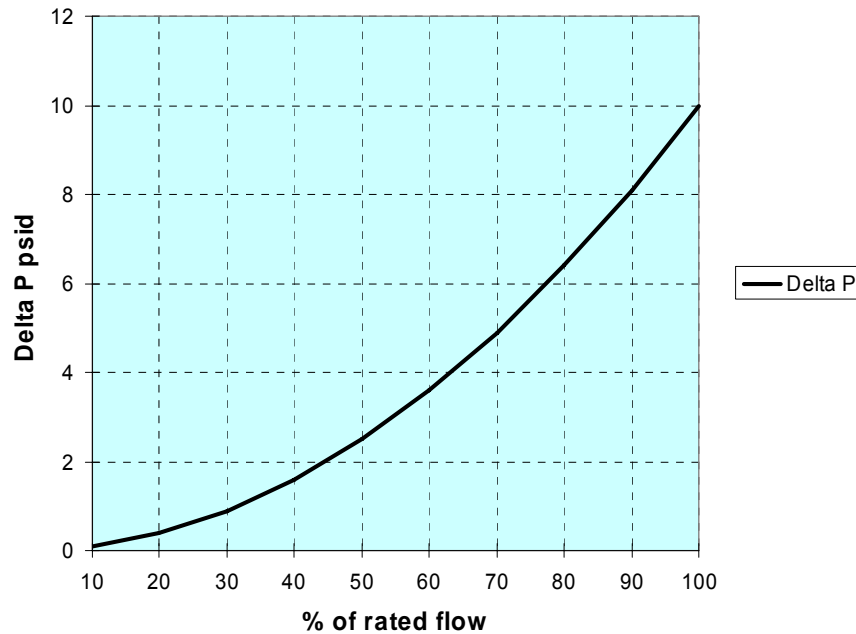

*For example:* You have a sensor with a 50-500 ml/min flow range (Range 5) and want to know the pressure drop (or minimum differential pressure required) at 300 ml/min. According to the calibration certificate, the pressure drop at 100% of flow is approx 10 psi. Using the formula above:

$$PD = (300 / 500)^2 \times 10 = 3.6 \text{ psid}$$

Therefore, at 300 ml/min the minimum required differential pressure for this unit is 3.6 psid. This means that if the available pressure is below 3.6 psid then flow

through the unit will not be possible.

Pressure drop through a system is cumulative. If the total pressure drop across all the components in a system exceeds the minimum pressure available then flow will not be possible.

*For example:* A system has a pressure of 30-40 psi. There are several components and the sum of their pressure drops at the required flow rate is 32 psid. If the system is operating at 30 psi flow would not be possible as the total of the pressure drops would be greater than the pressure available. The system will only operate if the system pressure is above 32 psi.

## 2. Mounting the FLO-SENSOR®.

McMillan FLO-SENSORS® have no particular installation requirements so may be mounted in any convenient position. It is recommended that the outlet of the FLO-SENSOR® is parallel with, or elevated above the inlet. This will enable entrapped air in the system to pass through the unit more easily.

### a) Mounting The Model 106

It is recommended that units be fixed to a suitable substrate with #4 screws using the two mounting holes provided.

*Mounting View From Bottom  
(Mounting hardware not included with sensor).*

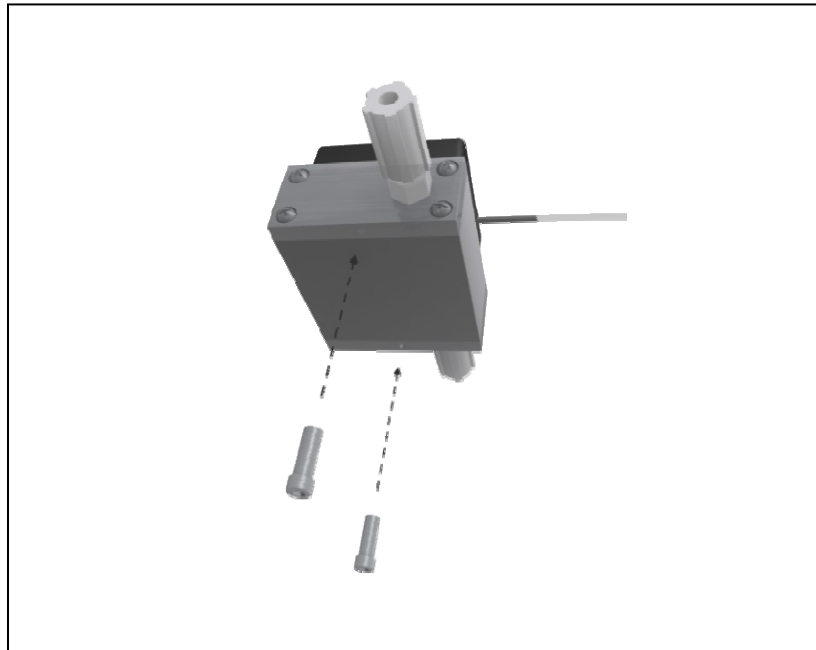

**b) Mounting The Model 106 Using an Optional Base-plate .**

An optional mounting base-plate (Part Number suffix "MT") is available for the Model 106 FLO-SENSOR®. This enables easy installation on flat, level surfaces.

The Model 106 FLO-SENSOR® and base-plate are pre-assembled at the factory. This assembled unit should be mounted on a suitable substrate using the two mounting holes provided.

*Mounting View From Side  
(Mounting hardware not included with sensor).*

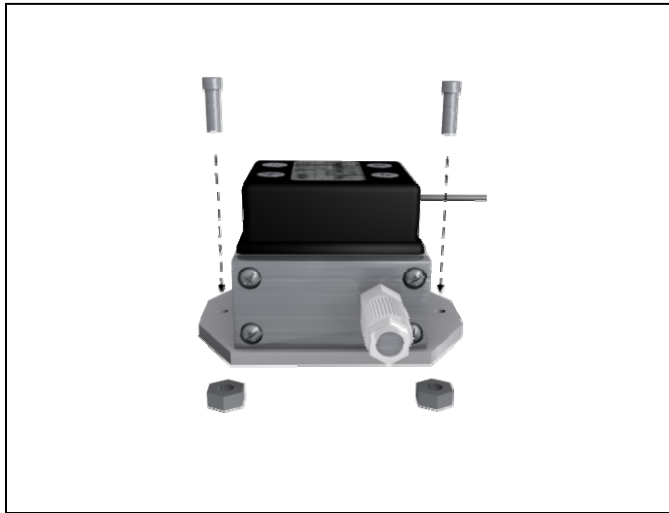

**c) Mounting The Model 106F and Model 106S**

The Model 106F and 106S FLO-SENSORS® have an integral base plate. Units should be mounted on a suitable substrate using the holes provided.

*Mounting View From Bottom  
Model 106S Shown, 106F is similar  
(Mounting hardware not included with sensor).*

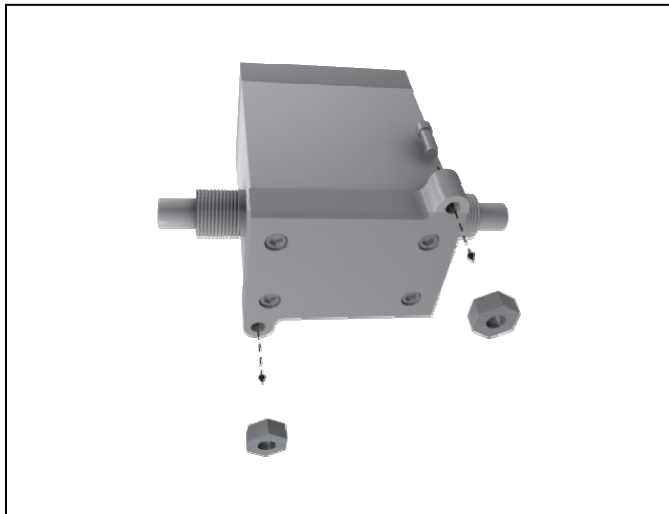



### 3. Tubing Connections

#### a) General



**CAUTION: DO NOT FLOW ANY GAS THROUGH A LIQUID FLO-SENSOR®. THIS WILL DAMAGE THE MICRO-TURBINE ASSEMBLY AND VOID THE WARRANTY.**

All tubing must be clean, dry and without crimps, burrs or scratches.

The flow direction for the FLO-SENSOR® is clearly marked on the label. Do not reverse the flow direction or the unit will not function.

*Close Up Of Label Showing Flow Direction  
(Model 106 shown, 106F and 106S Similar).*

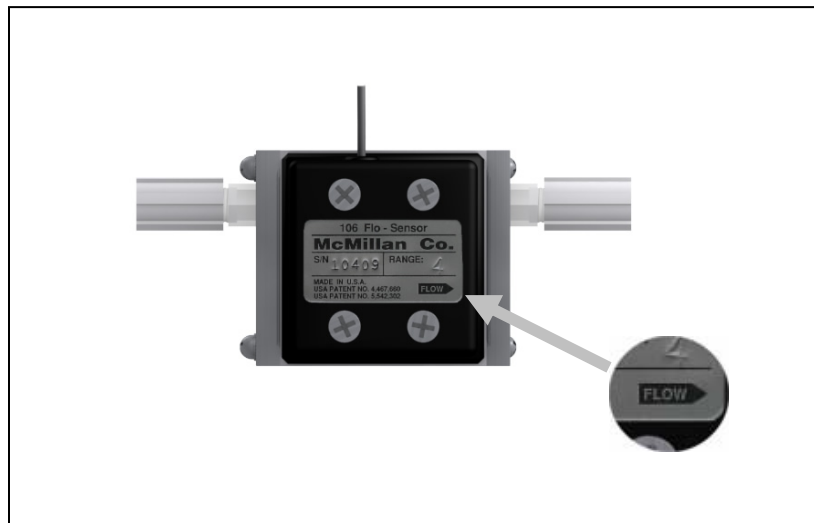

For the best results, the tubing ID should be as large as possible to avoid restrictions and turbulence. Straight lengths of tubing before or after the unit are not required.

#### b) Special Considerations For The Model 106.

Only use the fittings factory installed on the unit. If the fittings are removed the calibration of the unit may be effected and leaking may occur. If different fittings are required please contact the McMillan Company Service Department for assistance.



**Caution: DO NOT over tighten the fittings into the FLO-SENSOR® body. Excessive force may damage the sensor body and will NOT be repaired under warranty.**

When connecting the sensor to the tubing a wrench should be used to stop the fitting rotating in the sensor body. Take care not to over tighten the fittings or leaking may occur.

*Connecting and Tightening the Fittings  
(Model 106 only).*



#### 4. Electrical Connections



**Caution:** Incorrect wiring may cause severe damage to the unit. Applying an AC voltage (115VAC or 230VAC) directly to the unit will cause damage. Read the following instructions carefully before making any connections.

##### a) Overview

McMillan FLO-SENSORS® provide a 0-5 V DC, or 0-10 V DC, or 4-20 mA, or pulse output proportional to the flow rate. This output may be connected to a display, data acquisition system or voltmeter / current meter.

A regulated, stable and low noise D.C. power supply is recommended for powering the unit. The voltage and current requirements depend on the configuration of the unit. Full details may be found in the Specification section of this manual.

Connecting wires should be as short as possible to avoid voltage drops. Twisted 2 conductor cable should be used if the length of the power wires is to be longer than 1 meter.

Units are supplied with an integral cable terminated with pigtail leads. Electrical connections to the unit should be made as detailed in the following sections.

*Integral Cable Terminated with Pigtail Leads  
(Model 106 shown, 106F and 106S Similar).*

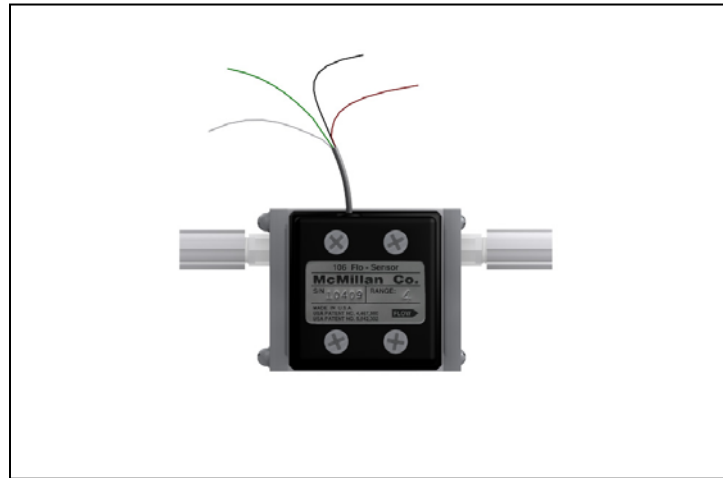

**b) Pulse Output Units ("A" or "E" Suffix )**

**i) NON ISOLATED Output**

If a NON ISOLATED output is required the same power supply as used for the flow sensor may be used to power the output. Connections should be made as follows:

*Wiring Schematic For Non Isolated Pulse Output. "A" or "E" Suffixes Only*

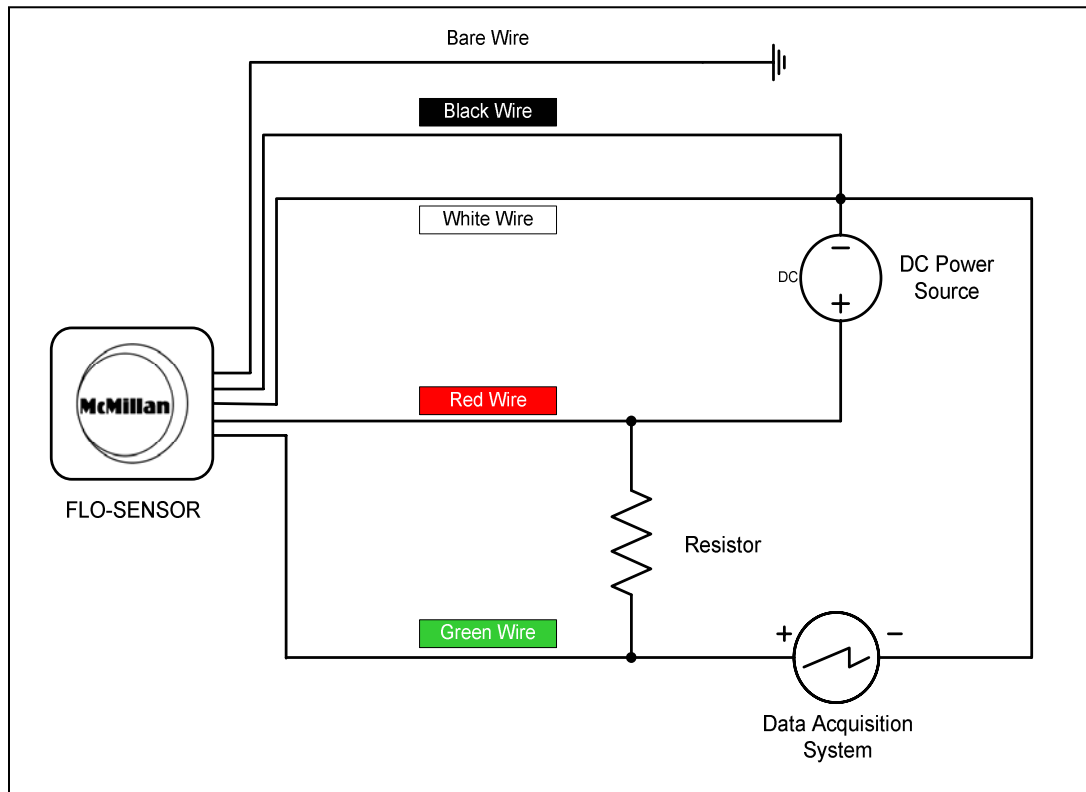

The **RED** wire should be connected to the Positive of the power source.

The **BLACK** wire should be connected to the Negative ( Ground ) of the power source.

The **WHITE** wire provides the pulse output and should be connected to the negative terminal of the power supply.

The **GREEN** wire is the pulse output and should be connected to the data acquisition system. A connection to the positive terminal of the power supply should be made using a resistor as shown above. For 12-15 VDC (A suffix) models, a 1000 ohm, 1/4 Watt minimum resistor should be used. For 18-24 VDC models, a 2000 ohm, 1/2 Watt minimum resistor should be used.

The **BARE** wire is the shield. For noisy environments this should be connected to ground (earth).

## ii) ISOLATED Output

If an ISOLATED output is required a low impedance, low noise power source needs to be connected to the pulse output wires. This should be isolated from the sensor power supply. Connections should be made as follows:

*Wiring Schematic For Isolated Pulse Output. "A" or "E" Suffixes Only*

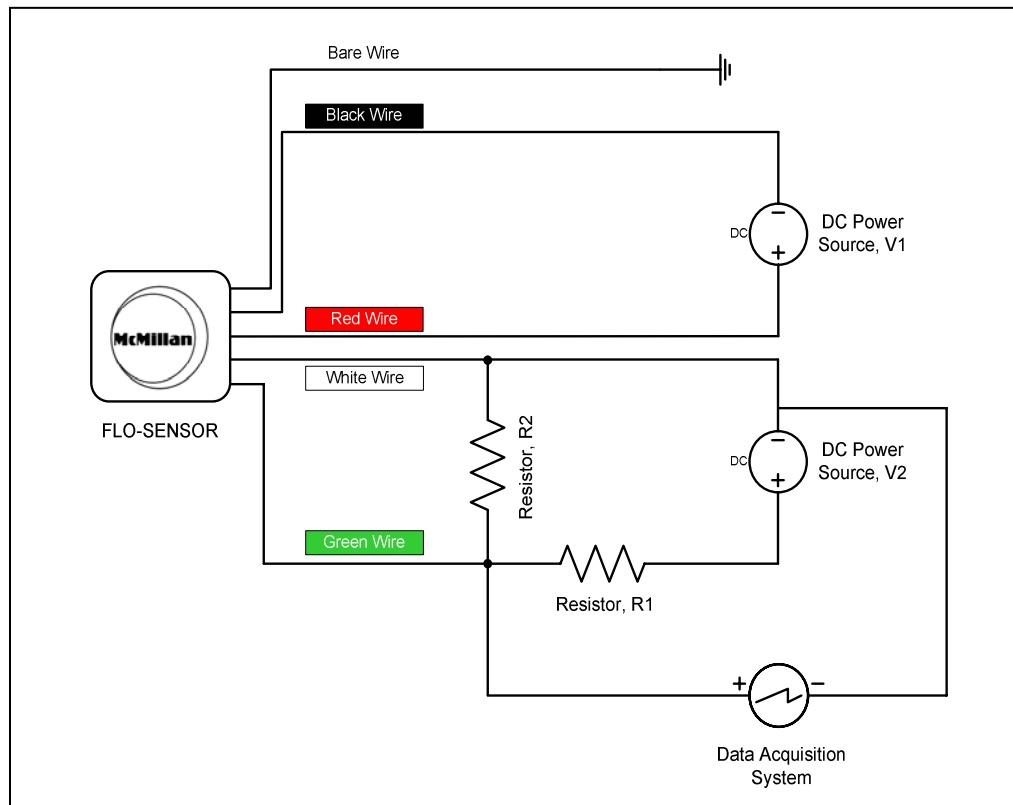

The **RED** wire should be connected to the Positive of the FLO-SENSOR<sup>®</sup> power source (V1).

The **BLACK** wire should be connected to the Negative ( Ground ) of the FLO-SENSOR<sup>®</sup> power source (V1).

The **GREEN** wire provides the pulse output and should be connected to the positive terminal of the data acquisition system. A connection to the positive terminal of the pulse output power supply (V2) using a resistor (R1) should also be made as shown above.

The **WHITE** wire is the pulse output and should be connected to the negative terminal of the data acquisition system using a resistor (R2). A connection to the negative terminal of the pulse output power supply (V2) should also be made as shown above.

The **BARE** wire is the shield. For noisy environments this should be connected to ground (earth).

The power supply (V2) connected to the pulse output should be less than 36VDC. Do not exceed a current of 20 mA through the FLO-SENSOR<sup>®</sup> BOSFET Pulse output.

The pulse output peak voltage may be calculated using the following formula:

$$V_{OUT} = V_2 (R_2 / ( R_1 + R_2 ))$$

$V_{OUT}$  is the pulse output peak voltage

$V_2$  is voltage applied to the output

$R_1$  and  $R_2$  are the resistance values of the resistors connected as shown above

Standard 5% composition type resistors may be used to provide the desired pulse voltage.

The resistor,  $R_2$  is not required if the frequency output voltage ( $V_{OUT}$ ) can be the same as the supply voltage,  $V_2$ .

If output isolation is not required then the sensor power supply ( $V_1$ ) can be used to power the pulse output ( $V_2$ ) as detailed in the previous section.



**Caution:** Avoid high voltage static discharges to the input signal connection. Do not short the input/output signal wires or allow them to contact the power wires at any time. **DAMAGE WILL RESULT!**

### c) Voltage Output Units ("B", "D", "J" and "K" Suffixes)

*Wiring Schematic Voltage Outputs. "B", "D", "J" or "K" Suffixes Only*

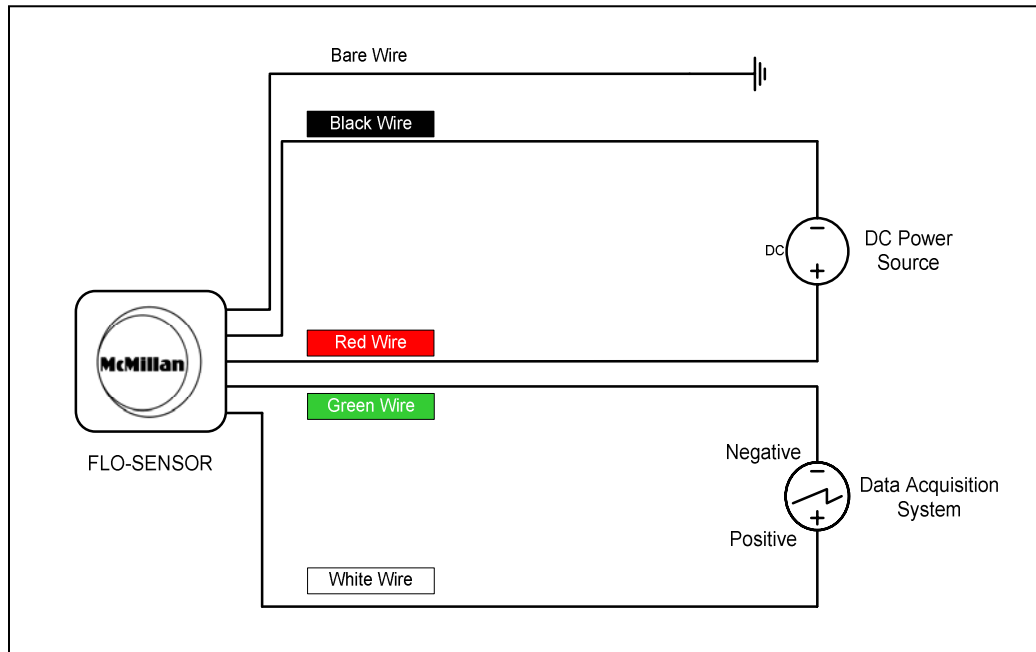

The **RED** wire should be connected to the Positive of the power source.

The **BLACK** wire should be connected to the Negative ( Ground ) of the power source.

The **WHITE** wire provides the signal output and should be connected to the positive terminal of the display, data acquisition system or voltmeter.

The **GREEN** wire is the signal negative (ground) and should be connected to the negative (Ground) terminal of the display, data acquisition system or voltmeter.

The **BARE** wire is the shield. For noisy environments this should be connected to ground (earth).

For 0-5 VDC units ("B" and "D" suffixes) the display, data acquisition system or voltmeter should have an impedance of greater than 2500 $\Omega$  (Ohms).

For 0-10 VDC units ("J" and "K" suffixes) the display, data acquisition system or voltmeter should have an impedance of greater than 5000 $\Omega$  (Ohms).



**Caution:** Avoid high voltage static discharges to the input signal connection. Do not short the input/output signal wires or allow them to contact the power wires at any time. **DAMAGE WILL RESULT!**

#### d) Current Output Units ("C" Suffix)

*Wiring Schematic For 4-20 mA Current Output. "C" Suffix Only*

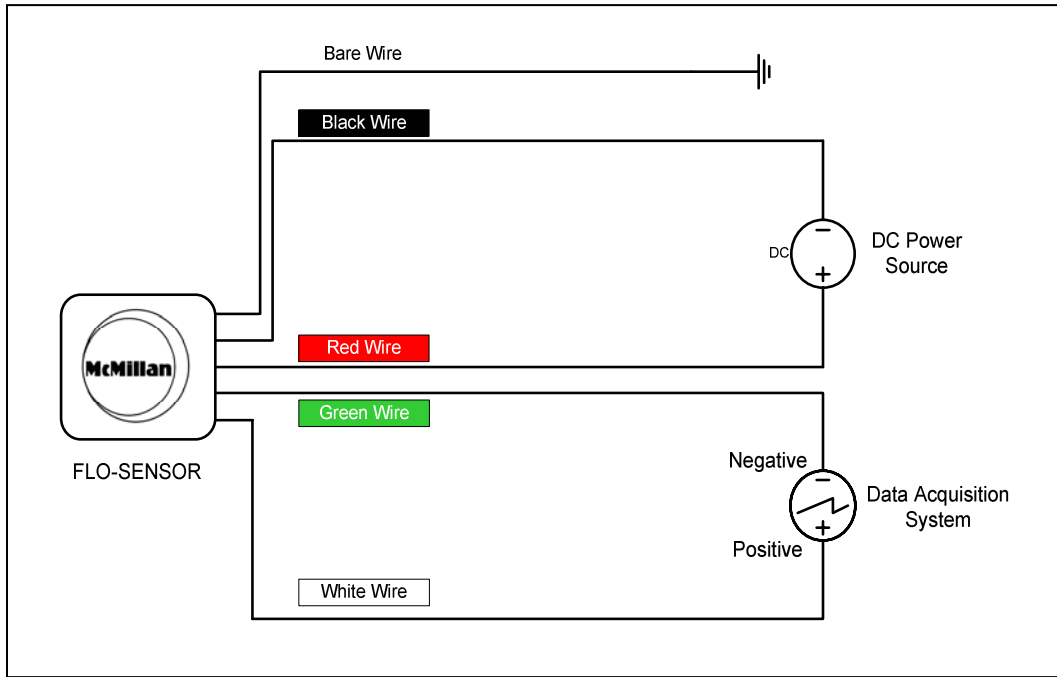

The **RED** wire should be connected to the Positive of the power source.

The **BLACK** wire should be connected to the Negative ( Ground ) of the power source.

The **WHITE** wire provides the signal output and should be connected to the positive terminal of the display, data acquisition system or current meter.

The **GREEN** wire is the signal negative (ground) and should be connected to the negative (Ground) terminal of the display, data acquisition system or current meter.

The **BARE** wire is the shield. For noisy environments this should be connected to ground (earth).

For 4-20 mA units ("C" suffix) the resistance of the external current loop should be less than 500  $\Omega$  (Ohms).



**Caution:** Avoid high voltage static discharges to the input signal connection. Do not short the output signal wires or allow them to contact the power wires at any time. **DAMAGE WILL RESULT!**

## C. *Operation*



**CAUTION: USE WITH LIQUIDS ONLY. FLOWING GAS OR AIR THROUGH YOUR FLO-SENSOR® WILL DAMAGE THE MICRO-TURBINE ASSEMBLY. THIS TYPE OF DAMAGE WILL NOT BE REPAIRED UNDER WARRANTY.**

### 1. **Start Up**

Before applying power to the unit check all tubing and electrical connections. Once correct installation is verified switch on the power.

### 2. **Entrapped Air or Gas**

There may be a lot of air or gas trapped in your FLO-SENSOR® after installation. This will usually escape the unit when flow (within the range of the unit) is first started.

If gas remains entrapped in the unit it may be necessary to elevate the outlet tubing above the inlet of the FLO-SENSOR®. This should enable the trapped gas to escape the unit. The tubing may be returned to its original position once all the gas has escaped.

If elevating the outlet tubing does not work, block or pinch the outlet tube whilst there is flow in the system. After approximately 5 seconds, release the restriction to allow normal flow. Doing this will build up pressure in the flow path that when released will help remove the entrapped gas. Repeat this several times until it is certain that all the entrapped gas has been removed from the unit. This can take some time for units with full scale flow rates of 500 ml/min and below (ranges 3, 4 and 5).

### 3. **Flow Readings**

McMillan FLO-SENSORS® provide a 0-5 VDC, or 0-10 VDC, or 4-20 mA, or pulse output proportional to the flow rate. The type of output signal is detailed in the part number reference and on the calibration certificate.

Each FLO-SENSOR® is factory calibrated for a specific flow range. The flow range is shown on the unit's label and calibration certificate. Units are calibrated using deionized water as the reference media.

#### **a) Pulse Output Units**

By monitoring the Pulse output frequency it is possible to determine the flow rate of the liquid. The pulse frequency for maximum flow through the unit (i.e. full scale



flow) is detailed on the calibration certificate. This differs from unit to unit. This output is approximately linear and scaleable within the sensor's range. For example:

For a flow range of 1.0-10.0l/min (Range 9) :

At 10.0l/min the pulse output signal detailed on the calibration certificate is 312Hz

If the output signal were 120Hz then the flow rate would be:

$$10.0 \div 312 \times 120 = 3.85\text{l/min}$$

### b) 0-5VDC Analog Outputs

By monitoring the voltage output signal it is possible to determine the flow rate of the liquid. Units are configured so that an output signal of 5.0VDC is provided when the maximum flow (i.e. Full Scale flow) is passing through the unit. The output signal is linear and scaleable enabling calculation of flow rates within the sensor's range. For example:

For a flow range of 50-500ml/min (Range 5) :

At 500ml/min the output signal would be 5VDC

If the output signal were 3.5VDC then the flow rate would be:

$$500 \div 5 \times 3.5 = 350\text{ml/min}$$

If the maximum flow rate is exceeded non-linear and inaccurate readings will result.

### c) 0-10VDC Analog Outputs

By monitoring the voltage output signal it is possible to determine the flow rate of the liquid. Units are configured so that an output signal of 10.0VDC is provided when the maximum flow (i.e. Full Scale flow) is passing through the unit. The output signal is linear and scaleable enabling calculation of flow rates within the sensor's range. For example:

For a flow range of 500-5000ml/min (Range 8) :

At 5000ml/min the output signal would be 10VDC

If the output signal were 6.9VDC then the flow rate would be:

$$5000 \div 10 \times 6.9 = 3450\text{ml/min}$$

If the maximum flow rate is exceeded non-linear and inaccurate readings will result.

#### d) 4-20mA Output Units

By monitoring the current output signal it is possible to determine the flow rate of the liquid. Units are configured so that an output signal of 20mA is provided when the maximum flow (i.e. Full Scale flow) is passing through the unit. The output signal is 4mA when there is zero flow through the unit. The output signal is linear and scaleable enabling calculation of flow rates within the sensor's range. For example:

For a flow range of 20-200 ml/min (Range 4) :

At 200 ml/min the output signal would be 20 mA

If the output signal were 9 mA then the flow rate would be:

$$200 \div (20-4) \times (9-4) = 62.5\text{ml/min}$$

#### 4. Operating at Flow Rates Outside the Calibrated Flow Range



**CAUTION:.** If the flow through the unit exceeds 120% of the maximum rated (full scale) flow the unit will be damaged. This type of damage will not be repaired under warranty.

Flow measurement is only accurate within the calibrated flow range for the unit. This is detailed on the calibration certificate. The unit will still operate, to some degree, outside this flow range.

Results obtained when operating outside the specified range of the unit are not accurate but may be considered repeatable.

##### a) Flows Above the Maximum Rated Flow.

If the flow rate is above the maximum rated (or full scale) flow, the unit will still operate and provide an output signal proportional to the flow rate.

Flows must not exceed 120% of the maximum rated flow or the unit may be damaged.

## b) Flows Below the Minimum Rated Flow.

Signal outputs may be obtained at flow rates below the minimum specified for your unit. The amount of flow that may be measured below the minimum specified varies from unit to unit.

## 5. Zero Adjustments

It is impossible for there to be any zero drift so zero adjustments are never required.



**NOTE:** Units with a 4-20 mA output signal (part number suffix C ) may have a slight offset at 4 mA. This is preconfigured at the factory during calibration and does not need adjustment.

## 6. Checking the Calibration

The calibration of the FLO-SENSOR<sup>®</sup> may be easily verified using empirical methods.

It should be noted that the use of empirical methods outside a certified calibration laboratory is subject to inaccuracy and error. These methods should only be used to gain an indication of a sensor's performance. Please contact the McMillan Service Department if accurate, certified recalibration is required.

A typical empirical calibration check may be carried out as follows:

Carefully adjust the flow rate so that the maximum output signal is obtained. With the flow rate constant, liquid flowing through the unit should be gathered in a container over a timed interval. The total volume flowed over the timed period should then be measured using a measuring cylinder. The actual flow rate (in the same units as the flow sensor calibration certificate) may then be calculated. The actual maximum flow rate should then be compared to the specified maximum flow rate to determine the error in calibration. For example:

For a flow range of 20-200ml/min (Range 4) with a 0-5VDC output:

With a constant flow and constant 5VDC output the actual volume measured over 30 seconds was 102ml.

Therefore the actual flow rate is:

$$(102 / 30) \times 60 = 204\text{ml/min}$$

The error is therefore  $204 - 200 = 4\text{ml/min}$  or 2%

Once the error in flow reading at maximum flow has been calculated, there are two options:

i.) Adjust the scaling endpoints in the display or data acquisition system. For example:

For a flow range of 50-500ml/min (Range 5) with a 0-5VDC output:

With a constant flow and constant 5VDC output the actual volume measured over 60 seconds was 405ml.

Therefore the actual flow rate is:

$$(405 / 60) \times 60 = 405\text{ml/min}$$

The display or data acquisition system may now be configured as follows:

0 VDC = Zero flow  
5VDC = 405ml/min

ii.) Apply the error factor to each flow reading taken. For example:

For a flow range of 0.2-2.0l/min (Range 7) connected to a display:

With a constant flow rate of 2.0 l/min on the display, the actual volume measured over 20 seconds was 0.7l

Therefore the actual flow rate is:

$$(0.7 / 20) \times 60 = 2.1 \text{ l/min}$$

The error is therefore  $2.1 - 2.0 = 0.1 \text{ l/min}$  or 5%

If the display shows an uncorrected flow rate of 1.4 l/min then :

$$\text{Corrected flow rate} = \text{Uncorrected flow rate} + \text{error} = 1.4 + 5\% = 1.47 \text{ l/min}$$

## 7. Calibrating FLO-SENSORS® for Different Liquids

McMillan FLO-SENSORS® will operate with most translucent liquids subject to compatibility of the wetted parts. Best results are obtained with low viscosity (less than 10 centistokes) liquids. For information regarding higher viscosity liquids, contact the McMillan Service Department.

Units are calibrated with deionized water as the reference media. Using other liquids will effect the calibration. The amount of calibration error will depend on the characteristics of the liquid being flowed.

The error in flow reading (or calibration) should be calculated and utilized as detailed in section 6 above.



**NOTE:** Some higher viscosity liquids may yield non linear results across the flow range. The calibration offset should be determined at several different flow rates across the range of the unit.

## ***D. Maintenance and Product Care***

### **1. General**



**CAUTION:** Do not disassemble your FLO-SENSOR® for any reason. If the unit appears to be malfunctioning please contact the McMillan Service Department.

McMillan FLO-SENSORS® require no periodic maintenance if used within the recommended specifications.

Inlet filters should be periodically checked and cleaned / replaced as necessary.

Regularly check all electrical and process connections for damage or deterioration.

If the sensor is to be stored, keep both the inlet and outlet ports sealed.

Do not store a FLO-SENSOR® with any chemical other than water (or air) inside it over an extended period of time. Prolonged exposure to chemicals other than water may lead to precipitation or corrosion.

### **2. Cleaning and Flushing**

If there is a build up of deposits or residues from the measured chemicals it may be necessary to clean *or flush* the unit. This should be done by flowing clean, particle free water through the unit at a flow rate, pressure and temperature within the specifications of the unit. If necessary, flow may be reversed to assist flushing.

Under no circumstances should gas or air be flowed through the unit. This will cause severe damage.

### 3. Returning Units for Repair or Recalibration

To return a unit for repair or recalibration please contact the McMillan Service Department or follow the procedure detailed on the McMillan web site. A Return to Manufacturer Authorization (RMA) number will then be issued to enable the unit to be returned. Please note that no returns will be accepted unless the RMA number is clearly indicated on the outside of all packages.

Once the unit has been received it will be evaluated and the cost of any repairs / recalibration determined. Once agreement has been received to pay for all the necessary work the unit will be processed and returned. No charges will be made for Warranty Repairs (see section ).

The McMillan Service Department may be contacted as follows:

**Mailing address:** McMillan Company  
P.O. Box 1340  
Georgetown, TX 78627  
U.S.A.

**Phone:** U.S.A. (512) 863-0231

**Fax:** U.S.A. (512) 863-0671

**Email:** [tech@mcmflow.com](mailto:tech@mcmflow.com)

**Website:** [www.mcmflow.com](http://www.mcmflow.com)

## E. Part Number Information

DESCRIPTION	CODE
Model 106 FLO-SENSOR®	106
Model 106F FLO-SENSOR®	106F
Model 106S FLO-SENSOR®	106S
Flow Range (ml/min of water)	
15-100 ml/min	3
20-200 ml/min	4
50-500 ml/min	5
100-1000 ml/min	6
200-2000 ml/min	7
500-5000 ml/min	8
1000-10000 ml/min	9
2.0-20.0 l/min	20
3.0-30.0 l/min	30
7.0-50.0 l/min	50
Power / Output Signal	
12.0-15.0 VDC / Pulse Output	A
22.0-25.0 VDC / 0-5 VDC Output	B
15.0-25.0 VDC / 4-20mA Output	C
12.0-15.0 VDC / 0-5 VDC Output	D
22.0-25.0 VDC / Pulse Output	E
22.0-25.0 VDC / 0-10 VDC Output	J
12.0-15.0 VDC / 0-10 VDC Output	K
Fittings	
1/8" PFA compression tube	T2
1/4" PFA compression tube	T4
3/8" PFA compression tube	T6
1/4" male flare (Flaretek® compatible)	F4
3/8" male flare (Flaretek® compatible)	F6
1/2" male flare (Flaretek® compatible)	F7
3/4" male flare (Flaretek® compatible)	F8
1/4" Super 300 (Pillar® compatible)	S4
3/8" Super 300 (Pillar® compatible)	S6
1/2" Super 300 (Pillar® compatible)	S7
3/4" Super 300 (Pillar® compatible)	S8
1" Super 300 (Pillar® compatible)	S9
Cable Length	
3 feet (0.92m)	C3
6 feet (1.85m)	C6
10 feet (3.1m)	C10
15 feet (4.6m)	C15
20 feet (6.2m)	C20
25 feet (7.7m)	C25
Options	
High Fluid Temperature Operation	HT
Add pair of PVDF Flare Nuts (Not Super 300)	FN
Upgraded Microturbine Wheel	U
Mounting Plate (Model 106 only)	MT
Exterior Teflon Coated (Model 106 only)	TX

Note: Please refer to the product datasheet for the availability of specific options.

## ***F. Accessories***

DESCRIPTION	CODE
<p><b>Cables and Power Adapters</b> (Ordered Separately)</p> <p>110VAC Power Adapter <i>For 15VDC Models with 0-5VDC output</i></p> <p>230VAC Power Adapter <i>For 15VDC Models</i></p>	<p>106-10-08</p> <p>106-10-18</p>
<p><b>Displays</b> (Ordered Separately, More Information Available)</p> <p>210R Rate Display, 3½ digit, 5-30 VDC Power</p> <p>250 Multi-Function Display, 115 VAC Power, Analog Input</p> <p>250E Multi-Function Display, 230 VAC Power, Analog Input</p> <p>251 Multi-Function Display, 115 VAC Power, Pulse Input</p> <p>251E Multi-Function Display, 230 VAC Power, Pulse Input</p>	<p>210R</p> <p>250</p> <p>250E</p> <p>251</p> <p>251E</p>



## G. Specifications

	Model 106	Model 106F	Model 106S
Accuracy (including linearity)	±1.0% Full Scale* ±3.0%* Full Scale for Pulse Output Units		
Repeatability	±0.2% Full Scale*		
Max Working Pressure	60 psig (4.2 bar)	80 psig (5.4 bar)	
Max Over Pressure Limit	80 psig (5.4 bar)	100psig (6.8bar)	
Temperature Rating (Fluid)	Operating Range: 5 to 55°C "HT" Option: 5 to 90°C		
Temperature Rating (Environment)	Operating: 5 to 55°C Storage: 0 to 70°C		
Temperature Sensitivity	±0.2% F.S.* or less per °C		
Wetted Materials	PTFE Sapphire PFA	PTFE Sapphire	
O-Ring Material	Perfluoroelastomer		
Non Wetted Materials	PTFE, Ryton, Viton, Polypropylene, Anodised Aluminum, Stainless Steel, PVC Jacketed Cable.	PTFE, Ryton, Viton, Polypropylene, Stainless Steel, PVC Jacketed Cable.	
Recommended Filtration	25 microns or less		
Compatible Liquids	Low viscosity (ideally <10cS) Translucent or transparent Minimum amount of entrapped air or gas		
Pulse Output Signal	BOSFET Opto isolated passive pulse Isolation 2500 volts Typically 0-200Hz for lower flow rates and 0-500Hz for higher flows Pulse height selectable using external voltage source		
0-5VDC Output Signal	Non Isolated Minimum 2.5 KΩ load		
0-10VDC Output Signal	Non Isolated Minimum 5 KΩ load		
4-20mA Output Signal	Non Isolated Current loop should be <500Ω		
Typical Power Consumption	12-15VDC units : 50mA 15-25 VDC units: 75mA 22-25VDC units: 50mA		
Response Time	Analog Outputs: Typically <1 second for 97% of final value Pulse Outputs: Typically <300 milliseconds for 97% of final value		
Reliability	100,000 hours MTBF		
Certifications	CE Approved 89/336/EEC (EN 55011 & EN 50082-1) 73/23/EEC Low Voltage Directive		
Ratings	IP53 (NEMA 2)		
Warranty	1 year limited		

\*Specifications from 10-100% of rated flow. Linearity is best fit straight line. All calibrations performed with deionized water unless otherwise stated on calibration certificate.

## H. Dimensions

### 1. Model 106 With 1/8" Compression Fittings

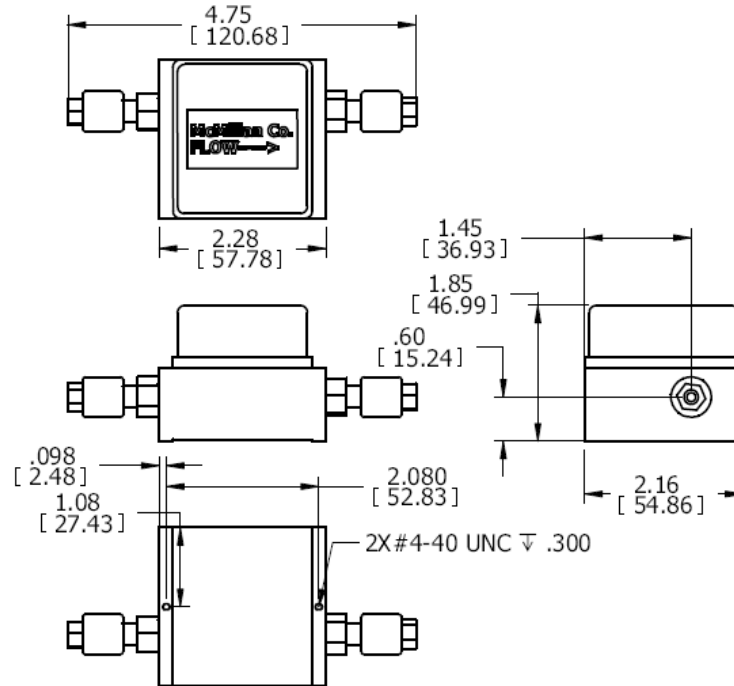

### 2. Model 106 With 1/4" Compression Fittings

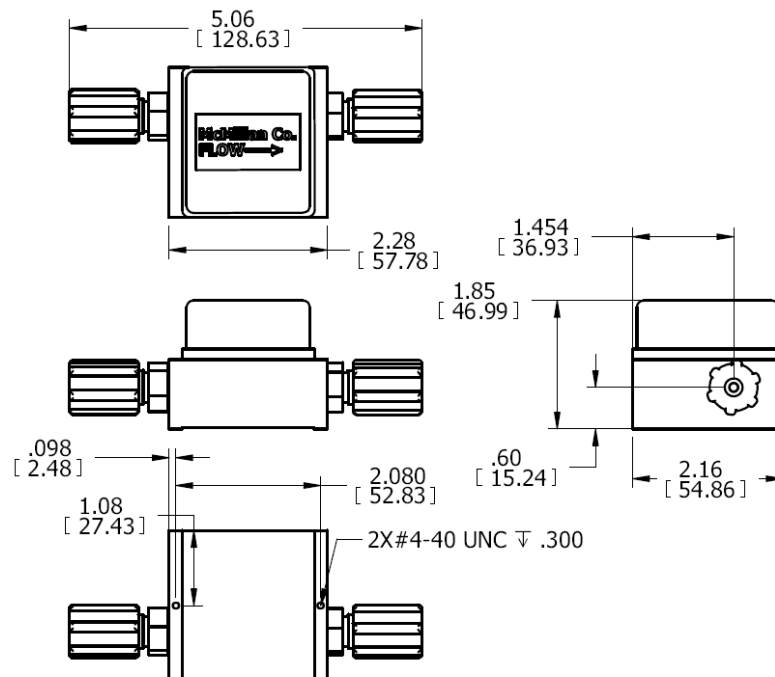

### 3. Model 106 With 3/8" Compression Fittings

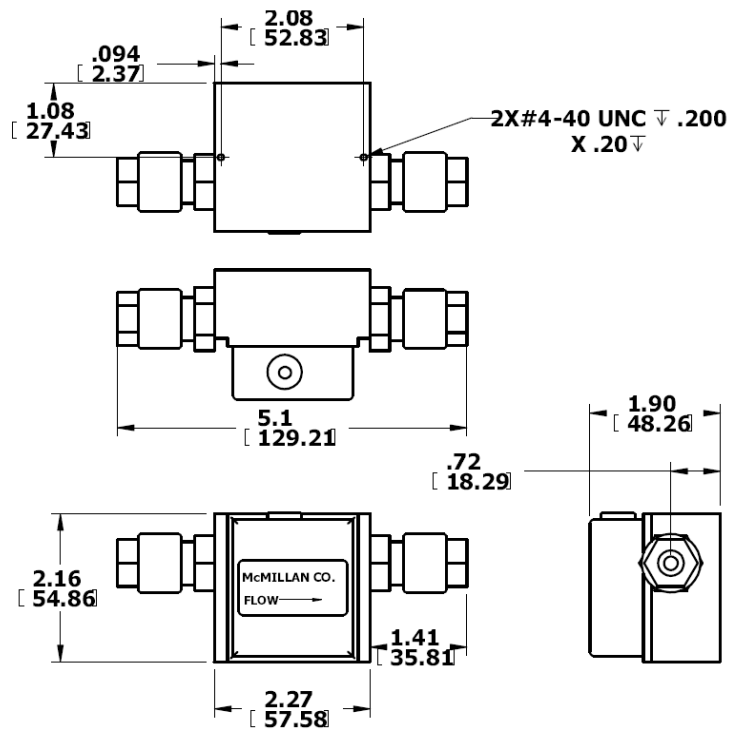

### 4. Model 106 With 1/4" Male Flare Fittings

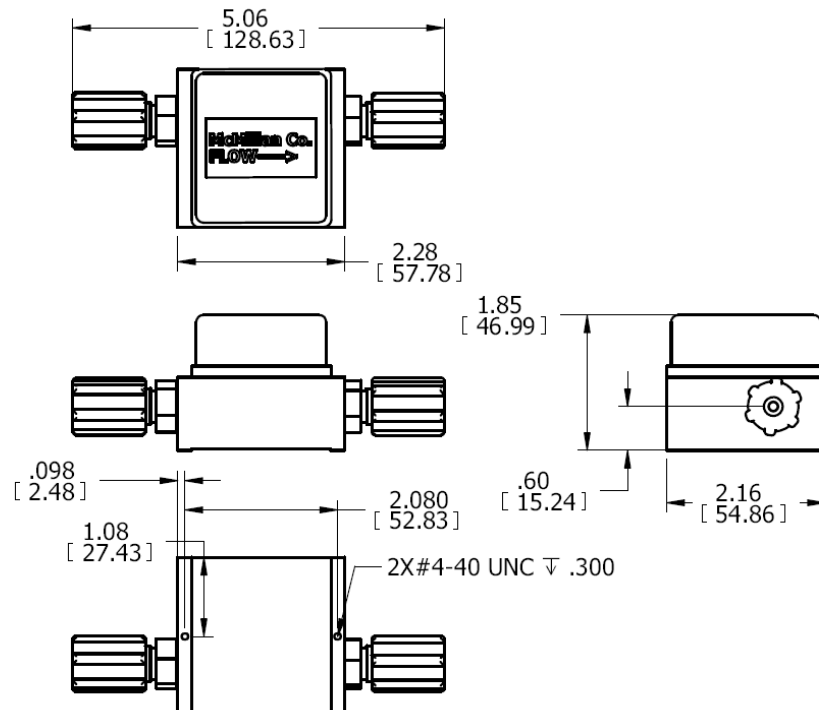

**5. Model 106 With 3/8" Male Flare Fittings**

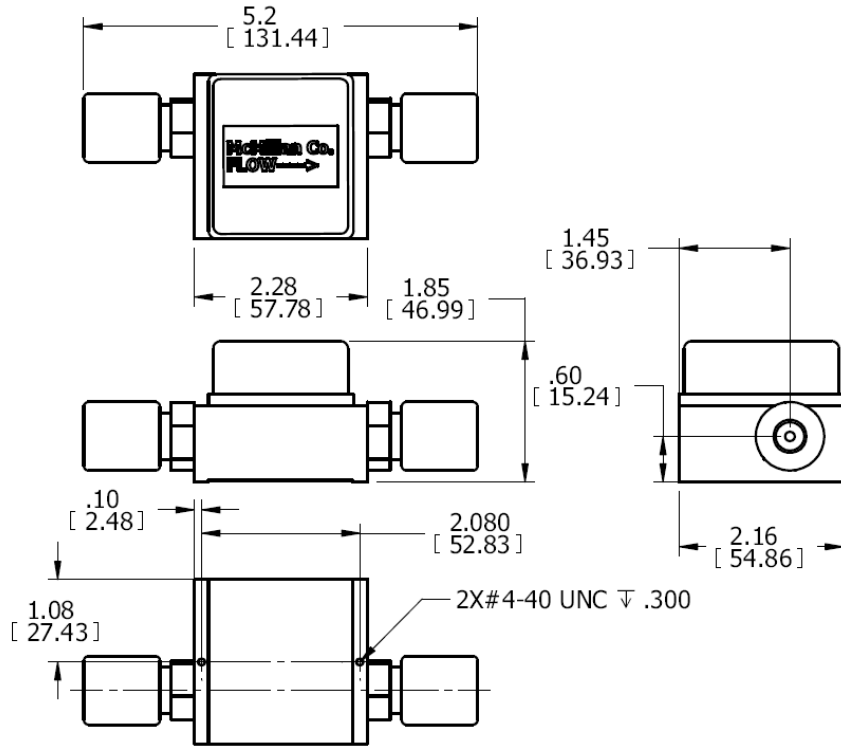

**6. Model 106 "MT" Mounting Plate**

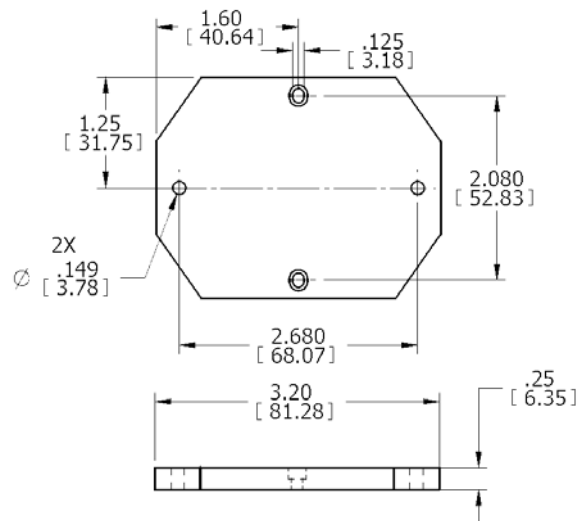



**9. Model 106S With 1/4", 3/8" or 1/2" Male Flare Fittings**

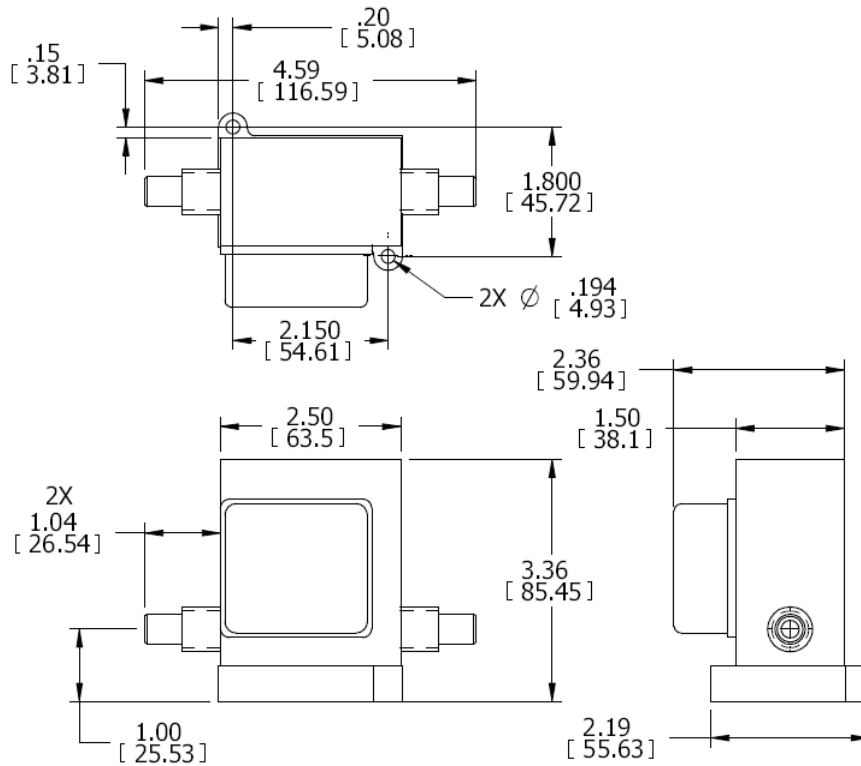

**10. Model 106S With 3/4" Male Flare Fittings**

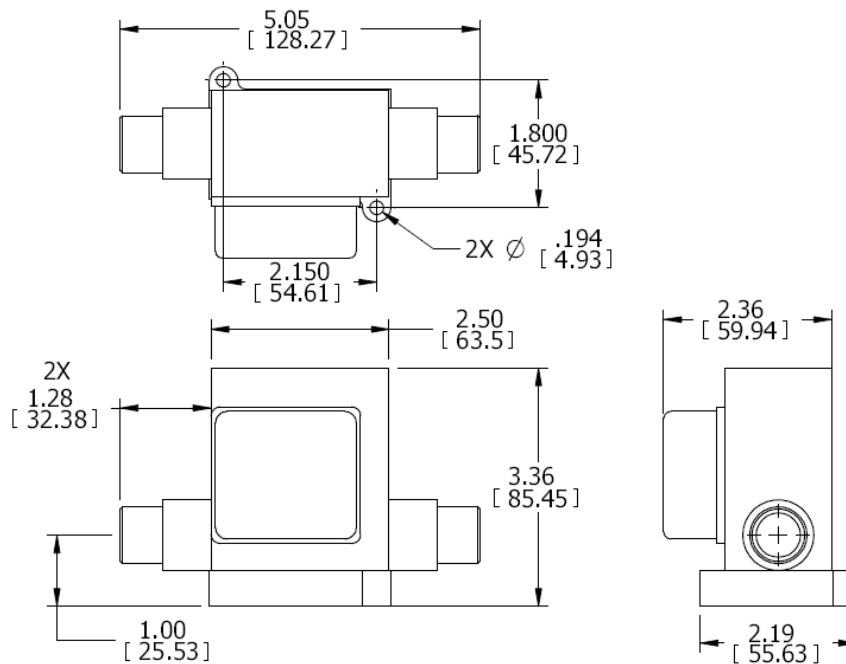

## 11. Model 106S With Super 300 Fittings

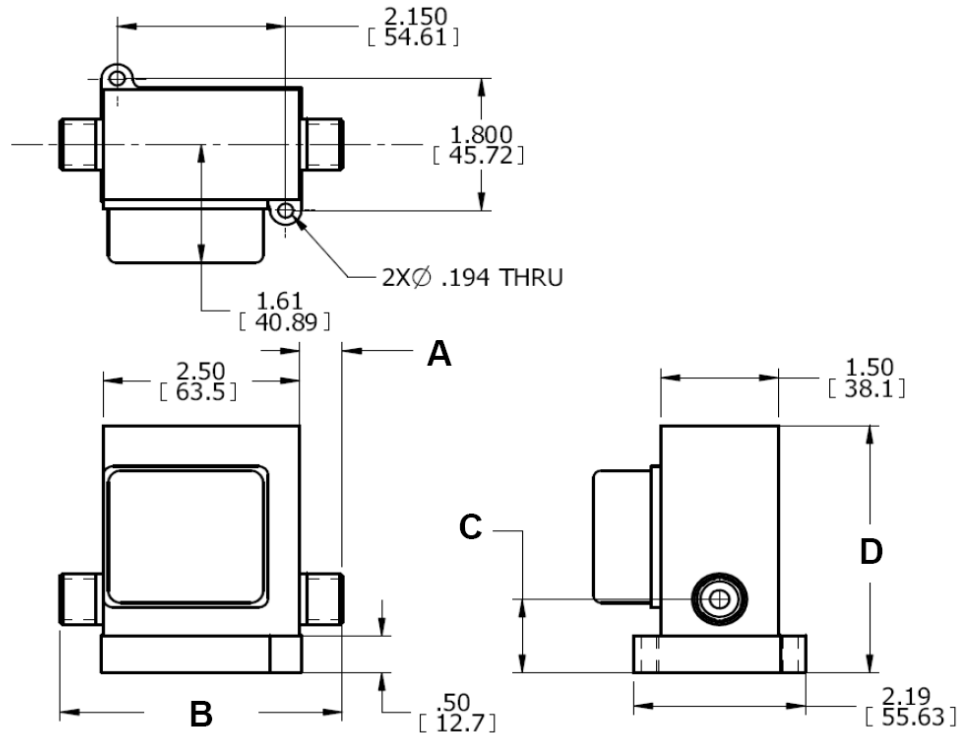

Fitting Size	P/N Suffix	Dimension			
		A	B	C	D
1/4" Super 300	S4	2 x 0.4" (2 x 11.43mm)	3.40" (86.36mm)	1.00" (25.40mm)	3.36" (85.45mm)
3/8" Super 300	S6	2 x 0.6" (2 x 13.97mm)	3.60" (91.44mm)	1.00" (25.40mm)	3.36" (85.45mm)
1/2" Super 300	S7	2 x 0.7" (2 x 17.78mm)	3.90" (99.06mm)	1.10" (27.94mm)	3.36" (85.45mm)
3/4" Super 300	S8	2 x 1.0" (2 x 25.40mm)	4.50" (114.30mm)	1.10" (27.94mm)	3.36" (85.45mm)
1" Super 300	S9	2 x 0.8" (2 x 20.32mm)	4.10" (104.14mm)	1.25" (31.75mm)	3.49" (88.62mm)

# I. **Limited Warranty**

## DURATION OF LIMITED WARRANTY, MATERIALS & WORKMANSHIP

R.D. McMillan Co., Inc., hereinafter referred to as "McMillan", warrants these products and their associated standard accessories manufactured by McMillan and supplied hereunder, to be free from defects in materials and workmanship for a period of twelve (12) months from the date of shipment to the customer when installed, serviced and operated in its recommended environment. This warranty is not affected in any part by McMillan providing technical support or advice.

Replacement parts are warranted to be free from defects in material or workmanship for ninety (90) days or for the remainder of the Limited Warranty period of the McMillan product in which they are installed, whichever is longer. Parts not installed by factory authorized service centers may void the warranty.

## PRODUCT RETURNS

### (a) **General Policy:**

Any product or parts determined by McMillan's inspection to have failed per this warranty, will at McMillan's option, be repaired or replaced with an equivalent or comparable product without charge. McMillan's obligation hereunder shall be limited to such repair and/or replacement and shall be conditional upon McMillan's receiving written notice of any alleged defect within ten (10) days of its discovery. The customer will, however, be responsible for returning the product to McMillan's manufacturing facility in Georgetown, Texas, U.S.A., and for assuming the cost of removing the original product and reinstalling the repaired or replaced product. A written specific explanation of the problem must be included with each returned product. Returned goods should be properly packaged to prevent shipping damage and shipped **prepaid** to McMillan.

### (b) **Safety Requirements:**

For safety reasons, McMillan must be advised of any hazardous fluid or toxic materials that were in or on the product to be returned. Customer must certify in writing that all such hazardous, corrosive or toxic substances have been completely removed, cleaned or neutralized from the returned product prior to shipment to McMillan. McMillan shall hold the returned items pending receipt of customer's statement for defect and certification of cleanliness of returned items, provided that, prior to such receipt, risk of loss of returned items shall remain with customer. Flow sensors, flow meters and flow controllers must be thoroughly cleaned to remove any toxic, corrosive or hazardous fluids that may internally remain therein before shipping product to McMillan.

### (c) **Shipping Requirements:**

Customer is responsible for all shipping charges (except for those products under warranty, in which cases customer shall bear the cost of inbound shipping as described herein below, and McMillan shall bear the cost of outbound shipping). Customer is responsible for the costs of out of warranty repairs and/or recalibration. McMillan will ship items repaired under warranty back to customer by the most economical shipping means. Expedited shipping methods may be available at customer's expense. All returned items shall be returned to a McMillan authorized service center., freight prepaid, accompanied or preceded by a particularized statement of the claimed defect and with a clearly readable Returned Material Authorization ("RMA") number affixed to the shipping label. Contact McMillan Customer Service Department for RMA number. Warranty claims shall be made only by using the McMillan's Returned Material Authorization form, completely filled out and returned to McMillan in accord with McMillan's Product Return Policy and Procedure Form.

**Contact McMillan's Customer Service Department as follows for instructions:**

**Telephone calls in U.S.A. (CST) 1-800-861-0231 or Outside U.S.A.  
512-863-0231 Or Fax: 1-512-863-0671 or e-mail: [sales@mcmflow.com](mailto:sales@mcmflow.com)**

## DESIGN, PROCESS and MANUFACTURING CHANGES

McMillan may make changes in the design or manufacture of any products sold hereunder without incurring any obligation to incorporate such changes into products manufactured prior to incorporation of such design or manufacturing changes. McMillan reserves the right to make design or manufacturing changes without prior notice. McMillan products and replacement parts are manufactured using new materials or new and equivalent to new in appearance, performance and reliability. Due to continuous research, testing, product improvements and enhancements, McMillan reserves the right to change product specifications without notice, except to the extent an outstanding bid obligation exists.

## LIMITATION of LIABILITY

Except as expressly set forth in this limited warranty, McMillan makes no other warranties or conditions, express or implied, including any implied warranties of merchantability and fitness for a particular purpose. McMillan expressly disclaims all warranties and conditions not stated in this limited warranty. Any implied warranties that may be imposed by law are limited in duration to the limited warranty period. Buyer/customer agrees that models or samples shown to buyer/customer were merely used to illustrate the purchased product and not to represent, promise or guarantee that any purchased products delivered hereunder would conform to such models or samples. McMillan's distributors or sales representatives have no authority to give warranties beyond those provided in this limited warranty.

If customer's product fails to work as warranted herein, customer's sole and exclusive remedy shall be the repair or replacement at McMillan's option. McMillan is not liable for any damages caused by the product or the failure of the product to perform, including any lost profits or savings, incidental or consequential damages. McMillan is not liable for any claim made by a third party or made by a buyer for a third party. No actions arising out of sale of the products sold hereunder or this limited warranty may be brought by either party more than two (2) years after the cause of action accrues. This limitation of liability applies whether damages are sought, or a claim made, under this limited warranty or as a tort claim (including negligence and strict product liability), a contract claim, or any other claim. This limitation of liability cannot be waived or amended by



any person. This limitation of liability will be effective even if customer has advised McMillan or an authorized representative or distributor of McMillan of the possibility of any such damages  
This limited warranty gives customer specific legal rights. Customer may also have other rights that may vary from state to state or country to country. Customer is hereby advised to consult applicable state or country laws for a full determination of customer's rights.

#### EXCLUSIONS FROM WARRANTY

This limited warranty provided herein **shall not apply** to any product which:

- (1) has been repaired or altered outside of McMillan's factory (or authorized service center) in any way so as, in McMillan's judgment, to affect such purchased item's reliability or performance.
- (2) has been subject to misuse, mishandling, negligence, accident, or acts of God.
- (3) has been operated other than in accordance with the printed instructions prepared by McMillan and provided by McMillan with the product.
- (4) has been returned to McMillan after more than thirty (30) days following the date of the alleged product failure.
- (5) has been returned to McMillan without complying with the Safety Requirements or the Shipping Requirements contained herein.
- (6) requires calibration and/or routine maintenance, unless this calibration or routine maintenance is required as a result of a product failure that is covered under terms of this warranty.
- (7) are consumable parts, such as filter elements, batteries or tube fittings.
- (8) requires replacement or repairs resulting from buyer's improper choice of product flow range, or require repair or replacement due to buyer subjecting product to corrosive fluids or other fluids not suited for use in product
- (9) has flow passages clogged due to failure to use a filter to protect product from particulates in fluid flow stream, or other cause to produce clogged passages
- (10) has been operated outside of recommended specifications (such as voltage, temperature, or flow range, etc.)
- (11) has been damaged or cracked due to negligence in failing to follow printed instructions to prevent excessive torque from being applied to product housing ( generally polyphenylene sulfide plastic )
- (12) has been damaged as a result of gross over-speeding, or prolonged over-speeding of the micro-turbine wheel
- (13) has been damaged as a result of severe sudden impact forces (example: dropping the product)

#### METHOD OF SETTLEMENT OF ANY CLAIMS, DISPUTES AND CONTROVERSIES

The provisions of this warranty are severable and if one or more provisions are deemed invalid, the remaining provisions shall remain in effect. Further, in the event that any provision is held to be over broad as written, such provision shall be deemed amended to narrow its application to the extent necessary to make the provision enforceable according to applicable law and shall be enforced as amended. This warranty shall be construed and interpreted in English.

All claims, disputes and controversies arising out of or relating in any way to claims under any warranties, either express or implied (including implied warranty of merchantability), or claims based on any consumer protection act or deceptive trade practice act, contract, tort, statute, or common law, or any alleged breach, default, and/or misrepresentation, will be resolved by means of final and binding arbitration. This limited warranty, including any contests to the validity or enforceability of this limited warranty, shall be finally settled by arbitration under the Rules of Conciliation and Arbitration of the International Chamber of Commerce by one or more of its arbitrators appointed in accordance with the Rules, and judgment upon award rendered may be entered in any court having jurisdiction thereof. The place of arbitration shall be Austin, Texas U.S.A., and the Texas Uniform Commercial Code, as then enacted shall govern the rights and duties of the parties of this agreement without regard to conflicts-of-law principles. The arbitration shall be conducted in English. The UN Convention on Contracts for the International Sale of Goods shall not apply to this Limited Warranty.

**R. D. McMillan Company, Inc.**  
**7075 R.R. 2338**  
**P. O. Box 1340**  
**Georgetown, Texas U.S.A. 78627**

## J. Troubleshooting Guide

Symptom	Possible Cause	Method of Correction
Unit Leaks	Fittings not tight enough	Tighten fittings (see section B4)
	Sensor assembly damaged	Unit must be returned for repair (see Section J)
No output signal or flow indication	No power or low power	Apply correct power
	No flow passing through unit	Display or output should read zero
	Output shorted or overloaded	Check electrical connections (see section B5)
	Improper connection	Check electrical connections (see section B5) and ensure connector is correctly plugged in
	Output circuitry damaged	Unit must be returned for repair (see Section J)
	Liquid not translucent enough.	Contact the McMillan Service Department for assistance
Flow indication "bounces" or fluctuates	Attempting to measure flows below the specified minimum for the unit	Use higher flow rates
	Flow is actually fluctuating	Correct flow source to obtain steady flow
	Not using the fittings supplied by the manufacturer	Use the supplied fittings
	Entrapped air or gas	Remove entrapped air (see section C2)
	Turbulence in tubing or sensor	Straighten the inlet tubing or lengthen it to at least 6" (150mm)
	Fluctuating input power	Correct the power source or change to a regulated supply
	Mechanical sensor assembly damaged	Unit must be returned for repair (see Section J)

Symptom	Possible Cause	Method of Correction
Flow indication is not linear and output too low at lower flows	Attempting to measure flows below the specified minimum for the unit	Use higher flow rates
	Liquid is too viscous	Best results are obtained with liquids that have a viscosity of 10cS or less. Contact the McMillan Service Department for further information
	Entrapped air or gas	Remove entrapped air (see section C2)
Flow reading accuracy is outside the specification	Mechanical sensor assembly damaged	Unit must be returned for repair (see Section J)
	Liquid has a different viscosity and / or specific gravity than water at 20°C	Calculate the flow reading error / offset as explained in section C7
	Entrapped air or gas	Remove the entrapped air (see section C2)
Flow indication is fixed at one value	Mechanical sensor assembly damaged	Unit must be returned for repair (see Section J)
	The maximum rated flow for the unit is being exceeded	Reduce the flow
	Output circuits may be damaged	Unit must be returned for repair (see Section J)

## ***K. Contacting McMillan***

**Website:** [www.mcmflow.com](http://www.mcmflow.com)  
**Email:** [tech@mcmflow.com](mailto:tech@mcmflow.com)

**Mailing address:** McMillan Company  
P.O. Box 1340  
Georgetown, TX 78627  
U.S.A.

**Shipping address:** McMillan Company  
7075 RR 2338  
Georgetown, TX 78628  
U.S.A.

**Phone:** (512) 863-0231  
**Fax:** (512) 863-0671

For repairs and/or return information, please contact our service department any of the ways shown above.

THIS PAGE INTENTIONALLY LEFT BLANK.

Manual 106-M001  
March 2006  
Revision 1  
[www.mcmflow.com](http://www.mcmflow.com)

THIS PAGE INTENTIONALLY LEFT BLANK.

Manual 106-M001  
March 2006  
Revision 1  
[www.mcmflow.com](http://www.mcmflow.com)